



FieldInternational

A World Of Experience To Keep You Flying



Field International Overview

Global Network 4 Manufacturing Sites 8 Sales Offices	Founded 1995	#1 Boeing Tooling Licensee
Certification ISO 9001:2015 ISO 14001:2015 ISO 22301:2019 AS9100 Rev D	+130,000 sqft of manufacturing space	Customers in over 50+ countries

Our Passion transfers into our service. Our aim, to offer most competitive price with the quickest lead time, as we are moving towards **Virtual Global Integrated Manufacturing**



Field International Limited HQ (UK)



Field International Shanghai Co. Ltd
China (SHANGHAI)



Field International Technologies PTE Ltd
Singapore



Field International Manufacturing India PVT
Ltd



The Foundation of Our Business

Management Philosophy of Field International Group

We aim to exceed the expectations of stakeholders and communities through the pursuit of our corporate vision and mission, acting in accordance with our values which form the foundation of our business decisions.

VISION

Build better futures by overcoming the most complex,
profound challenges, everywhere

MISSION

We aspire to be the leading team, with consistent commitment towards tomorrow's demand in Aerospace and Defence. We take pride in the high level of services and solutions we provide to all our customers across all sectors.



Safety & Quality

We are committed to the highest standards of safety and quality in everything we do



Collaboration

We enable our people to work seamlessly across geographies and functions towards mission accomplishments



Customer Focus

We are committed to listen to our customers needs and strive to achieve customer experience excellence



Support our People

We embrace diversity, develop and retain our people with competences to create new value



Build an organization with Integrity

We are uncompromising in our ethical behavior and protecting our company culture, which foster trustworthiness with one another, our customers, suppliers and strategic partners



FieldInternational

**Culture Drives
Performance**

**Performance
Creates Value**



Approvals and Endorsements



- **Field International Ltd UK**

BS EN 9100:2018, ISO9001:2015 & AS9100 Rev D (Cert No. FM562029)
Cage Code K0697

- **Field International PTE Ltd**

ISO 9001:2015 (Cert No. FS668234)
BOEING Licence (Agreement No. 2022-36JCB5H)
Cage Code Q3629

- **Field International Technologies PTE Ltd**

ISO 9001:2015 (Cert No. ASA-00410)
ISO 14001:2015 (Cert No. ASA-00411)
ISO 45001:2018 (CErt No. ASA-00412)
ISO 22301:2019 (Cert No. ACS-0164)
Bizsafe Level STAR (Cert No. E32411)
Cage Code Q3657

- **Field International Shanghai Co. Ltd**

ISO 9001:2015 (Cert No. QAIC/CN/121581)
BOEING Licence (Agreement No. 2019-31YPCMW)

- **Field International Manufacturing India PVT Ltd**

ISO 9001:2015 approval planned for Q1 2024
Cage Code 6509Y

- **Field International Engineering & Consultancy PVT Ltd**

ISO 9001:2015 approval planned for Q1 2024
Cage Code 6357Y

- **Field International Middle East LLC**

ISO 9001:2015 (Cert No. FS 782377)
Cage Code 4FMLW
Technical Tool Services: calibration, proof load testing, annual servicing

Major OEM customers:

- Airbus Defense & Space (Tier 1)
- Airbus Helicopters (Tier 1)
- BAE Systems (Tier 1)
- Boeing Aircraft Tooling Licensee
- Bombardier
- Collins Aerospace
- Lufthansa Technik
- Rolls-Royce
- Rolls-Royce Naval



In addition to the OEM approvals, we proudly support the majority of major Airlines and MRO's around the world with manufactured licensed aircraft tooling and GSE.

Refer to our website for more information





Our Business - AEROSPACE



Field International is proud to be one of the top selling Boeing tooling licensees. We manufacture, calibrate, repair and supply tooling for the complete Boeing range of aircraft. We have recently enjoyed huge success with manufacturing B787 tooling by converting sales of 70% of quoted tooling to the Airlines and MRO.

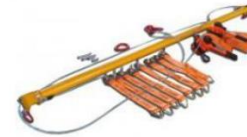

B71040
Sling Eqpt Inlet Cowl



C27056
Sling Equipment Leading Edge Slat



J54009
Sling Eqpt Strut Aft Fairing

AIRBUS

Helicopter Tooling



Field International is proud to be one of the few Tier 1 suppliers to Airbus Helicopters.



A320 Sharklet Tool



Leap 1A Engine Stand



M632V10101
Left Accessory Module Support



M632V1005102
Main Gearbox Support



FIL 8400



FIL 8400 is the only Airbus approved A380 landing gear removal / installation tool

FIL 8100



FIL 8100 is the only Airbus approved A330-A340 landing gear removal/installation tool

FIL 3300 – Oil Migration Tool



Designed and developed following a request by Airbus.

The tool measures the amount of oil leakage through the landing gear seals, enabling maintenance organisations to accurately determine when the landing gear oil seals need to be replaced.

This has reduced the unnecessary replacement of the seals and prevented downtime and cost.

FIL 8700 – A380 Air Generation Unit Installation & Removal Trolley





Engineered Solutions

Beluga Door, Tooling Design, Manufacture & Installation into 1st Aircraft

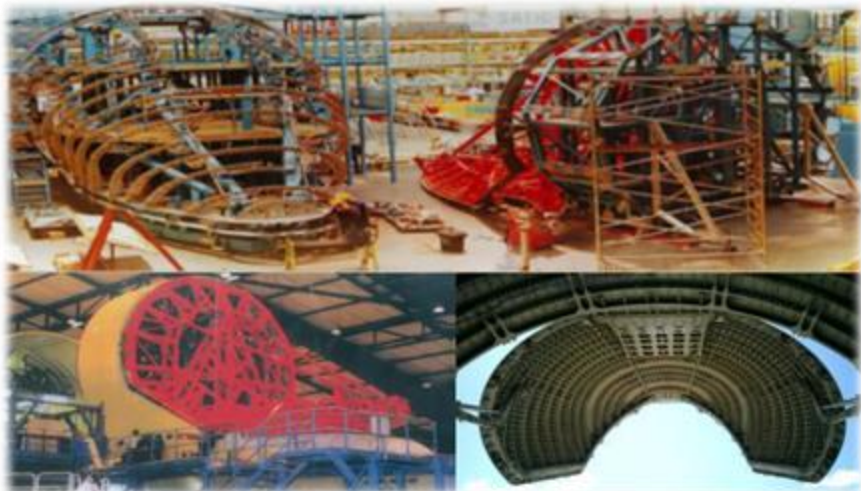

TUV London Underground



Air Conditioning Unit
Removal/Installation Tool

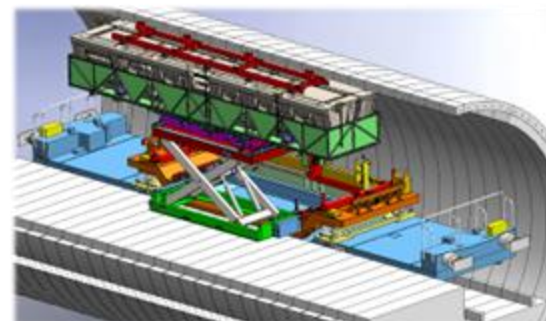

A320 Wing Transportation Jig

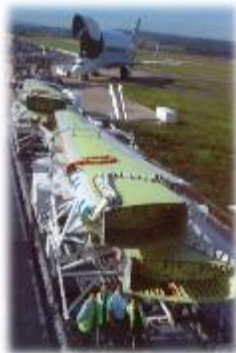

Field successfully re-designed and manufactured the jigs reducing the weight of the originals by 52% enabling Airbus to transport two sets of A320 wings in the Beluga aircraft.

Design, manufacture and Installation of Second Stage A320 Skin Panel Jig in Broughton, Wales UK.



Vestas Design & Build Project

Assembly Jig, to position reinforcing Webs ready to assemble into 80m wind turbine blade.

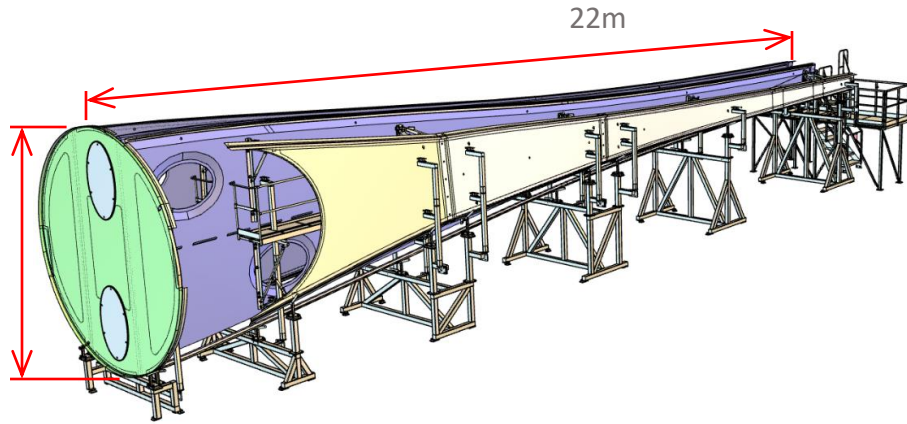

Jig overview, loaded with Webs

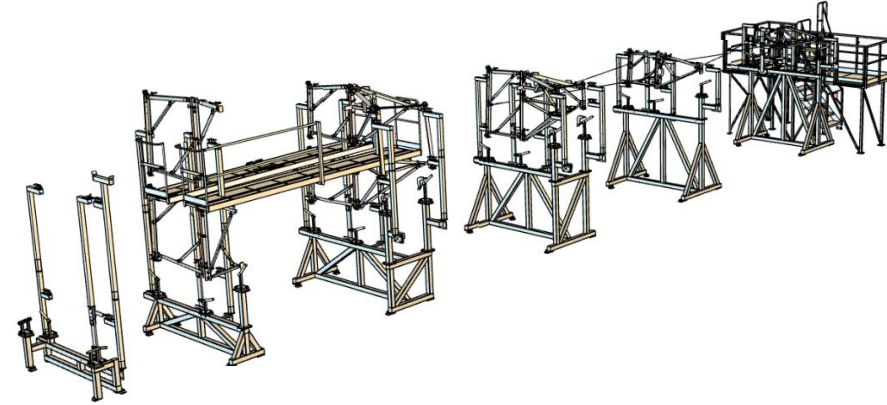

All Jig parts in relative positions, with end platform and intermediate walkways



Centre of Excellence Plan (future)

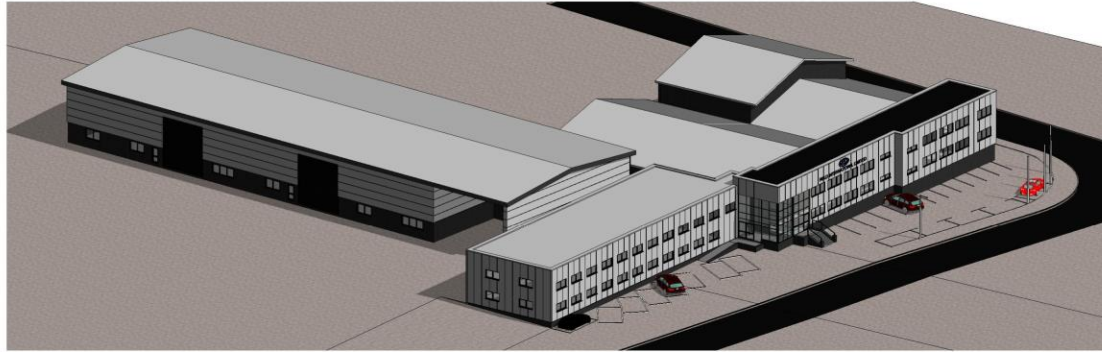

bird's view



3D View 6

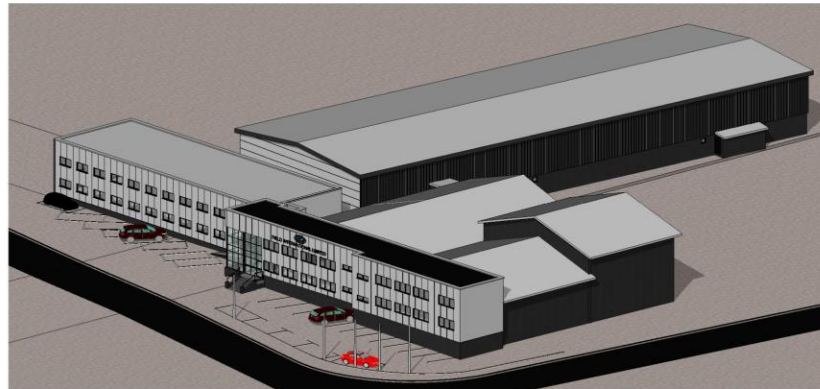

bird's view 2

Proposed Elevations for 22-24 Nuffield Road and New Link
at
22-24 Nuffield Road
Poole, Dorset
for
FIELD INTERNATIONAL LTD

Date: April 2019 Scale: NOT TO SCALE Drawn: D.A.

PERSPECTIVES

4635

25



ARCHITECTS
UNIT 11, FULCRUM BUSINESS PARK
VALENTINE WAY, POOLE
DORSET, BH12 4NA
TEL: (01202) 723157
FAX: (01202) 745464
E-MAIL: office@lonegregory.co.uk





FieldInternational

Field Aeronautica, SL

Sales - Central/South America and Southern Europe

Alfonso Aguila Gonzalez

Sales Executive

Tel: +34 629269708

Email: alfonso@fieldinternational.com

Field International Limited

Group Head Office, Manufacturing, Design and Sales
UK

Ben Chalmers

Group Sales and Marketing Director

Office Tel: +44 1202 676331

Mob: +44 7852 297309

Email: benchalmers@fieldinternational.com

Field International (Zhejiang) Co. Ltd

Manufacturing
China

Wu Zheng Yu

Operations Director

Tel: +86 (573) 82288500

Mob: +86 13816330465

Email:

wuzhengyu@fieldinternational.net

Field International PTE Ltd

Tooling Head Office and Sales
Asia Pacific

Dave Soh

Director APAC Sales

Tel +65 6542 8061

Mob: +65 9011 3338

Email: davesoh@fieldinternational.com

Field International Technologies PTE Ltd

Manufacturing
Asia Pacific

Dave Soh

General Manager

Tel +65 6264 0886

Mob: +65 9011 3338

Email: davesoh@fieldinternational.com

Field International Middle East Mechanical Equipment Trading LLC

Sales & Technical Services
Middle East, Türkiye & Eastern Europe

Ulf (Wolf) Peter

GM & VP Customer Programs

Phone: +971 2 5647008

Sales Email: SalesME@fieldinternational.com

Tech Services Email: Techservicesme@fieldinternational.com

Refer to our website for more information



Field International Aerospace, LLC

Sales Office
North America and Canada

Mike Krupsky

VP of Sales - North America

Tel: +1 817 901 8875

Email: mikekrupsky@fieldinternational.com

Field International Engineering & Consultancy Private Limited

93/66 Kalavai Street, Chintadripet
Chennai, 600002 India.

Madras Mohan Vishnu Kanth

Business Head - India

Tel: +91 989 450 4140

Email: vishnu@fieldinternational.com