



**Field**International

A World Of Experience To Keep You Flying



# Field International Overview

<b>Global Network</b> 4 Manufacturing Sites 8 Sales Offices	<b>Founded 1995</b>	<b>#1</b> Boeing Tooling Licensee
<b>Certification</b> ISO 9001:2015 ISO 14001:2015 ISO 22301:2019 AS9100 Rev D	+130,000 sqft of manufacturing space	Customers in over <b>50+</b> countries

**Our Passion** transfers into our service. Our aim, to offer most competitive price with the quickest lead time, as we are moving towards **Virtual Global Integrated Manufacturing**



Field International Limited HQ (UK)



Field International Shanghai Co. Ltd  
China (SHANGHAI)



Field International Technologies PTE Ltd  
Singapore



Field International Manufacturing India PVT  
Ltd



# The Foundation of Our Business

## Management Philosophy of Field International Group

We aim to exceed the expectations of stakeholders and communities through the pursuit of our corporate vision and mission, acting in accordance with our values which form the foundation of our business decisions.

### VISION

Build better futures by overcoming the most complex,  
profound challenges, everywhere

### MISSION

We aspire to be the leading team, with consistent commitment towards tomorrow's demand in Aerospace and Defence. We take pride in the high level of services and solutions we provide to all our customers across all sectors.



#### **Safety & Quality**

We are committed to the highest standards of safety and quality in everything we do



#### **Collaboration**

We enable our people to work seamlessly across geographies and functions towards mission accomplishments



#### **Customer Focus**

We are committed to listen to our customers needs and strive to achieve customer experience excellence



#### **Support our People**

We embrace diversity, develop and retain our people with competences to create new value



#### **Build an organization with Integrity**

We are uncompromising in our ethical behavior and protecting our company culture, which foster trustworthiness with one another, our customers, suppliers and strategic partners



FieldInternational

**Culture Drives  
Performance**

**Performance  
Creates Value**



# Approvals and Endorsements



- **Field International Ltd UK**

BS EN 9100:2018, ISO9001:2015 & AS9100 Rev D (Cert No. FM562029)  
Cage Code K0697

- **Field International PTE Ltd**

ISO 9001:2015 (Cert No. FS668234)  
BOEING Licence (Agreement No. 2022-36JCB5H)  
Cage Code Q3629

- **Field International Technologies PTE Ltd**

ISO 9001:2015 (Cert No. ASA-00410)  
ISO 14001:2015 (Cert No. ASA-00411)  
ISO 45001:2018 (CErt No. ASA-00412)  
ISO 22301:2019 (Cert No. ACS-0164)  
Bizsafe Level STAR (Cert No. E32411)  
Cage Code Q3657

- **Field International Shanghai Co. Ltd**

ISO 9001:2015 (Cert No. QAIC/CN/121581)  
BOEING Licence (Agreement No. 2019-31YPCMW)

- **Field International Manufacturing India PVT Ltd**

ISO 9001:2015 approval planned for Q1 2024  
Cage Code 6509Y

- **Field International Engineering & Consultancy PVT Ltd**

ISO 9001:2015 approval planned for Q1 2024  
Cage Code 6357Y

- **Field International Middle East LLC**

ISO 9001:2015 (Cert No. FS 782377)  
Cage Code 4FMLW  
Technical Tool Services: calibration, proof load testing, annual servicing

## Major OEM customers:

- Airbus Defense & Space (Tier 1)
- Airbus Helicopters (Tier 1)
- BAE Systems (Tier 1)
- Boeing Aircraft Tooling Licensee
- Bombardier
- Collins Aerospace
- Lufthansa Technik
- Rolls-Royce
- Rolls-Royce Naval



In addition to the OEM approvals, we proudly support the majority of major Airlines and MRO's around the world with manufactured licensed aircraft tooling and GSE.

Refer to our website for more information





# Our Business - AEROSPACE



Field International is proud to be one of the top selling Boeing tooling licensees. We manufacture, calibrate, repair and supply tooling for the complete Boeing range of aircraft. We have recently enjoyed huge success with manufacturing B787 tooling by converting sales of 70% of quoted tooling to the Airlines and MRO.



Field International

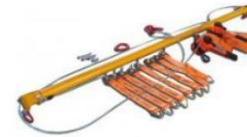

B71040  
Sling Eqpt Inlet Cowl



C27056  
Sling Equipment Leading Edge Slat



J54009  
Sling Eqpt Strut Aft Fairing



A320 Sharklet Tool



Leap 1A Engine Stand

## AIRBUS

Helicopter Tooling



Field International is proud to be one of the few Tier 1 suppliers to Airbus Helicopters.



M632V10101  
Left Accessory Module Support



M632V1005102  
Main Gearbox Support



*FIL 8400*



FIL 8400 is the only Airbus approved A380 landing gear removal / installation tool

*FIL 8100*



FIL 8100 is the only Airbus approved A330-A340 landing gear removal/installation tool

*FIL 3300 – Oil Migration Tool*



Designed and developed following a request by Airbus.

The tool measures the amount of oil leakage through the landing gear seals, enabling maintenance organisations to accurately determine when the landing gear oil seals need to be replaced.

This has reduced the unnecessary replacement of the seals and prevented downtime and cost.

*FIL 8700 – A380 Air Generation Unit Installation & Removal Trolley*





## Engineered Solutions

Beluga Door, Tooling Design, Manufacture & Installation into 1<sup>st</sup> Aircraft

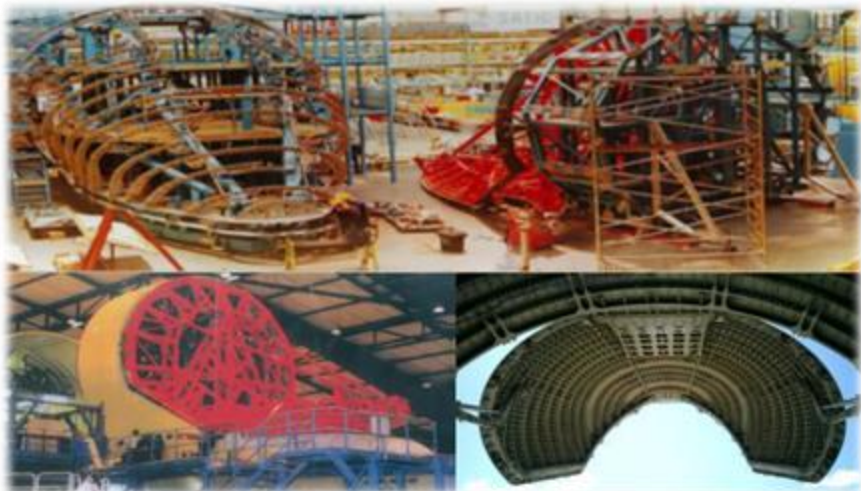

TUV London Underground



Air Conditioning Unit  
Removal/Installation Tool

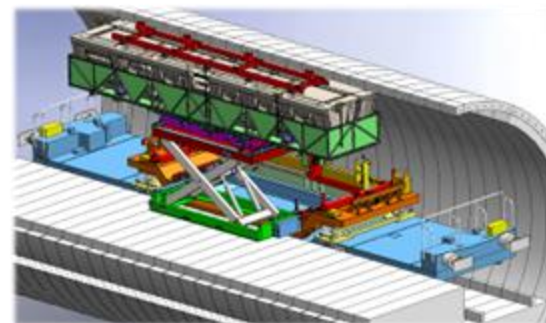

A320 Wing Transportation Jig

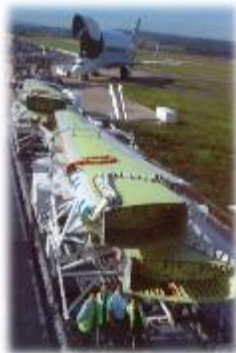

Field successfully re-designed and manufactured the jigs reducing the weight of the originals by 52% enabling Airbus to transport two sets of A320 wings in the Beluga aircraft.

Design, manufacture and Installation of Second Stage A320 Skin Panel Jig in Broughton, Wales UK.



## Vestas Design & Build Project

Assembly Jig, to position reinforcing Webs ready to assemble into 80m wind turbine blade.

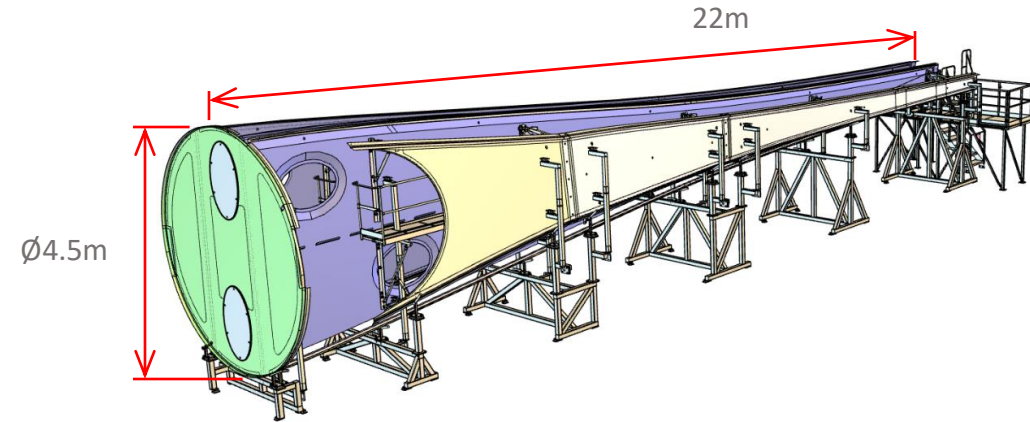

Jig overview, loaded with Webs

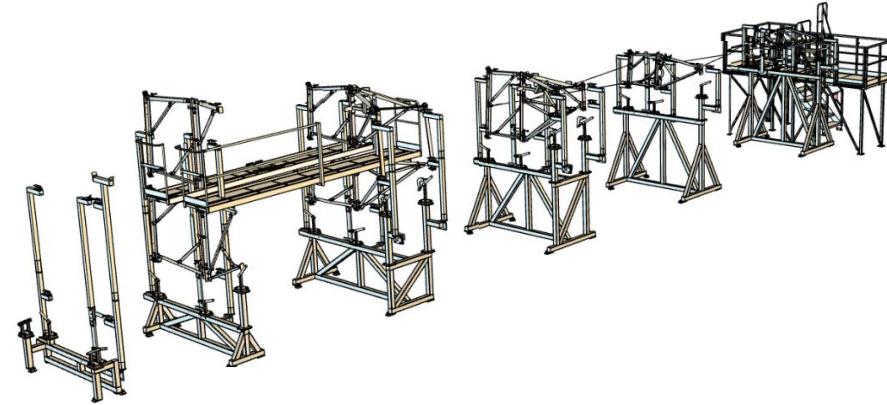

All Jig parts in relative positions, with end platform and intermediate walkways





Our Defence Business

# Past and present experience with BAE Systems



Field International UK is proud to be one of the Tier 1 suppliers to BAE Systems and other international defence customers since 1995. Our core capabilities include in-house engineering design, manufacturing including welding, painting, hydraulic cleaning and vehicular/sub-system integration of combat support vehicles



## Tooling

Field International has supplied tooling for the M777 supporting welding, heat treatment, assembly & in-service operation.



## M777 LRP & FRP production

1200 + plus sets have been supplied to BAE Systems in support of low and full rate production over the life of the project. Engineering & Design support has also been a major factor in Field International's relationship with BAE Systems with the M777 resulting in 2 awards presented by the DoD in the USA.

## Hypak Project

1000 sets of Hypak have been supplied to BAE Systems in support of an upgrade to the M777 hydraulic system.

## LCS Spares

Integrated component solutions covering component and spares.



## A400M Engineered Solutions

Tooling Support –Rudder Removal & Installation Tool



Airbus A400M Cargo Door Removal & Installation Tool



Field was requested, in separate projects, to design and manufacture a solution to remove and install the rudder and cargo door. We were given very short lead-times with a designated window to gain access to the aircraft. We succeeded despite the short lead-time and difficult on-site conditions.

# Specialist Projects



## Land System Engineering and Manufacturing

- Engineering Design and Development
- 3D dynamic simulation
- Complete turnkey project services



## Integration of Productive Specialty Vehicles

- Custom truck bodies and trailers
- Emergency response vehicles

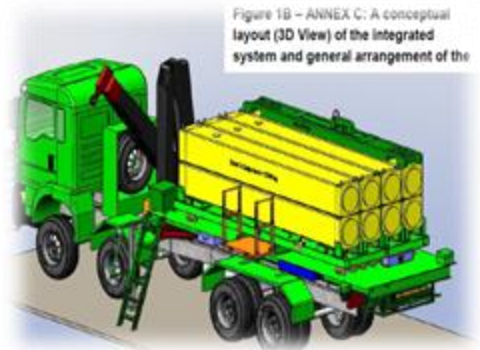

## Component Total Support

- Integrated component solutions covering component and spares

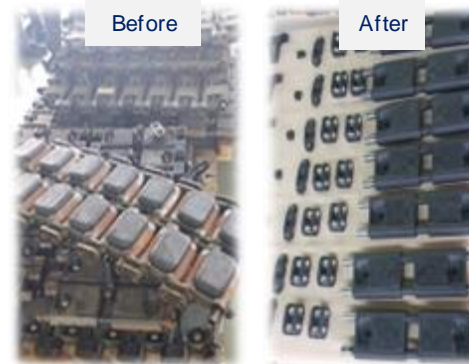

## Maintenance and Modification

- Modifications, upgrading and refurbishments
- Customized sub-system upgrades



## Total Support Services

- Accredited testing and inspection



# Centre of Excellence Plan (future)

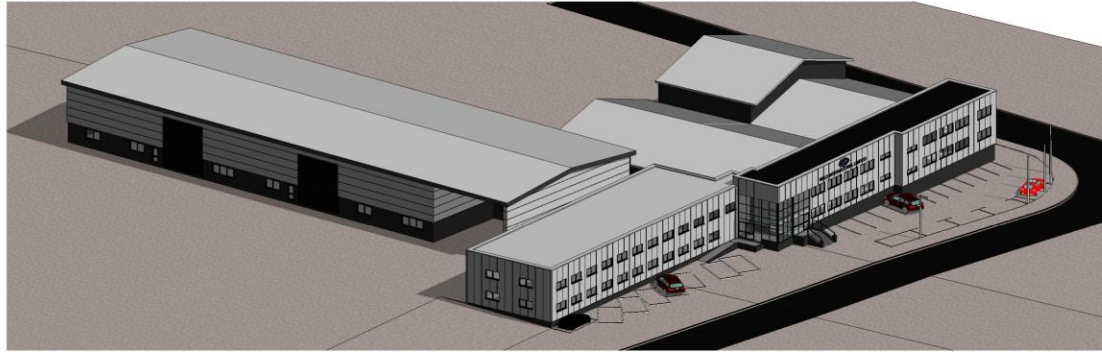

bird's view



3D View 6

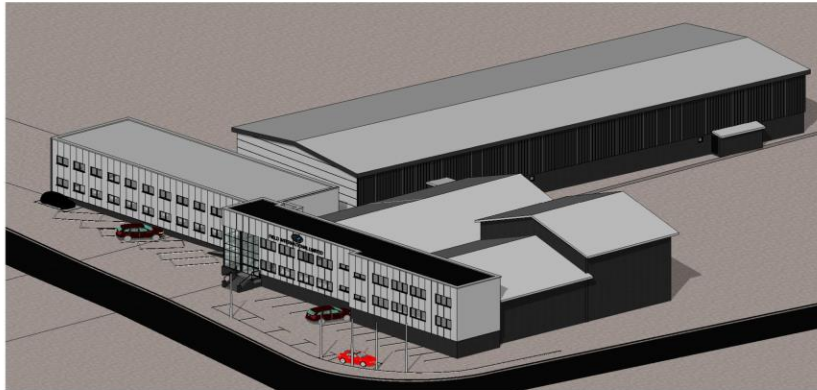

bird's view 2

Proposed Elevations for 22-24 Nuffield Road and New Link  
at  
22-24 Nuffield Road  
Poole, Dorset  
for  
FIELD INTERNATIONAL LTD

Date: April 2019    Scale: NOT TO SCALE    Drawn: D.A.

PERSPECTIVES

4635

25



**ARCHITECTS**  
UNIT 11, FULCRUM BUSINESS PARK  
VALENTINE WAY, POOLE  
DORSET, BH12 4NA  
TEL: (01202) 723157  
FAX: (01202) 745464  
E-MAIL: office@lonegregory.co.uk





**Field**International

**Field Aeronautica, SL**

Sales - Central/South America and Southern Europe

**Alfonso Aguila Gonzalez**

Sales Executive

Tel: +34 629269708

Email: [alfonso@fieldinternational.com](mailto:alfonso@fieldinternational.com)

**Field International Limited**

Group Head Office, Manufacturing, Design and Sales  
UK

**Ben Chalmers**

Group Sales and Marketing Director

Office Tel: +44 1202 676331

Mob: +44 7852 297309

Email: [benchalmers@fieldinternational.com](mailto:benchalmers@fieldinternational.com)

**Field International (Zhejiang) Co. Ltd**

Manufacturing  
China

**Wu Zheng Yu**

Operations Director

Tel: +86 (573) 82288500

Mob: +86 13816330465

Email:

[wuzhengyu@fieldinternational.net](mailto:wuzhengyu@fieldinternational.net)

**Field International PTE Ltd**

Tooling Head Office and Sales  
Asia Pacific

**Dave Soh**

Director APAC Sales

Tel +65 6542 8061

Mob: +65 9011 3338

Email: [davesoh@fieldinternational.com](mailto:davesoh@fieldinternational.com)

**Field International Technologies PTE Ltd**

Manufacturing  
Asia Pacific

**Dev Soh**

General Manager

Tel +65 6264 0886

Mob: +65 9011 3338

Email: [davesoh@fieldinternational.com](mailto:davesoh@fieldinternational.com)

**Field International Middle East Mechanical Equipment Trading LLC**

Sales & Technical Services  
Middle East, Türkiye & Eastern Europe

**Ulf (Wolf) Peter**

GM & VP Customer Programs

Phone: +971 2 5647008

Sales Email: [SalesME@fieldinternational.com](mailto:SalesME@fieldinternational.com)

Tech Services Email: [Techservicesme@fieldinternational.com](mailto:Techservicesme@fieldinternational.com)

Refer to our website for more information

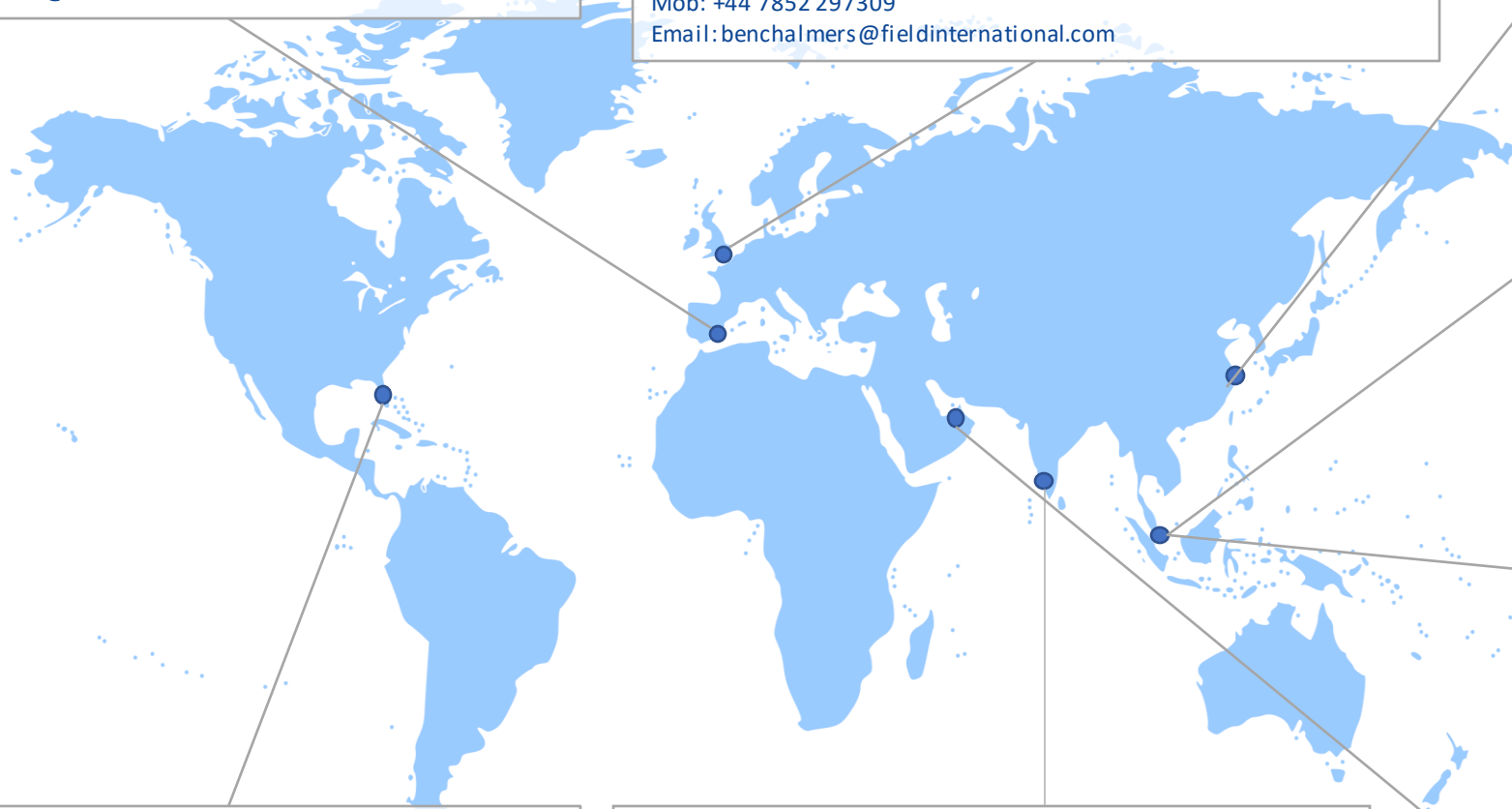

**Field International Aerospace, LLC**

Sales Office  
North America and Canada

**Mike Krupsky**

VP of Sales - North America

Tel: +1 817 901 8875

Email: [mikekrupsky@fieldinternational.com](mailto:mikekrupsky@fieldinternational.com)

**Field International Engineering & Consultancy Private Limited**

93/66 Kalavai Street, Chintadripet  
Chennai, 600002 India.

**Madras Mohan Vishnu Kanth**

Business Head - India

Tel: +91 989 450 4140

Email: [vishnu@fieldinternational.com](mailto:vishnu@fieldinternational.com)